

CON-E-CO[®]

An Oshkosh Truck Corporation Company

Batchmaster concrete batch plant

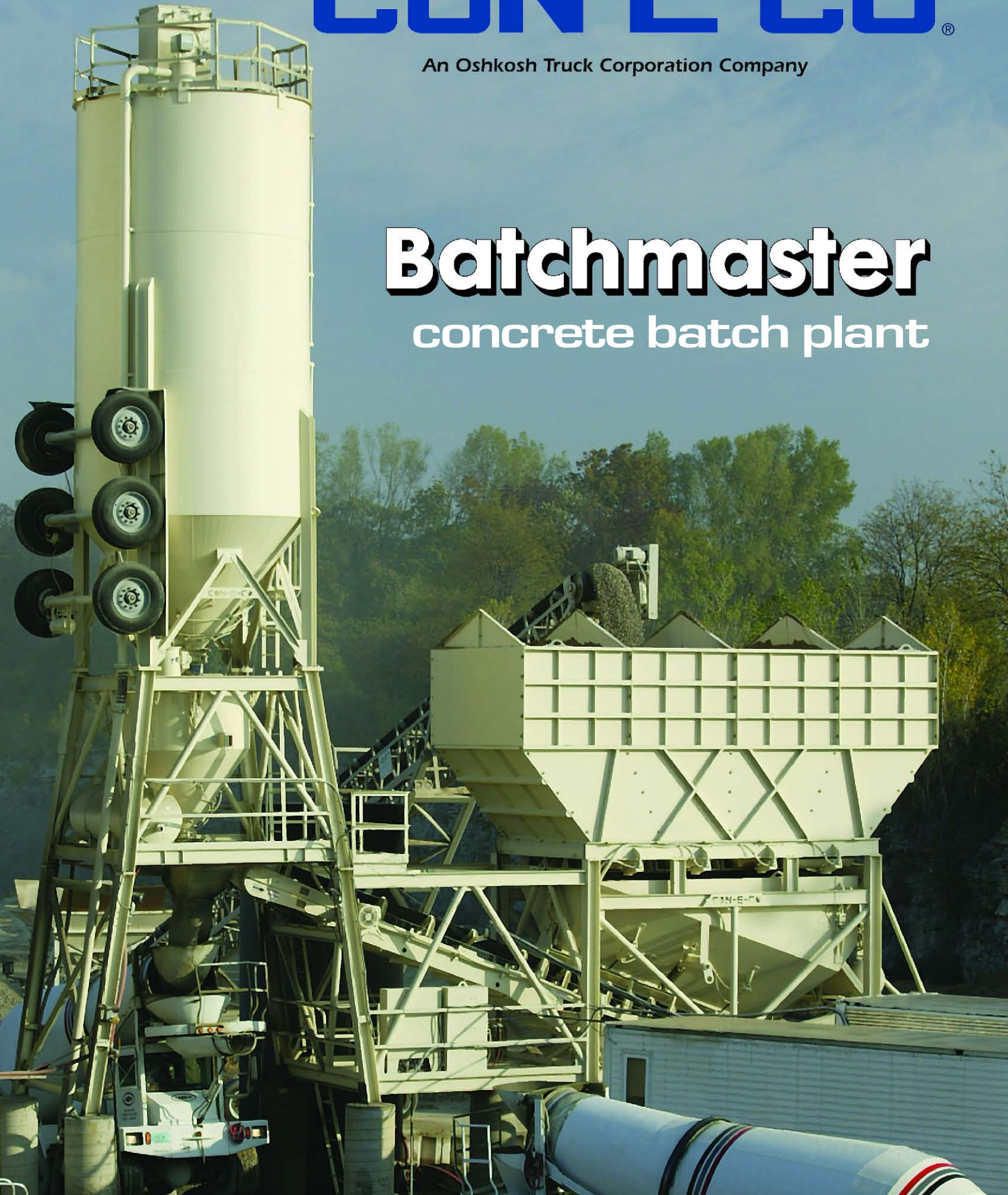

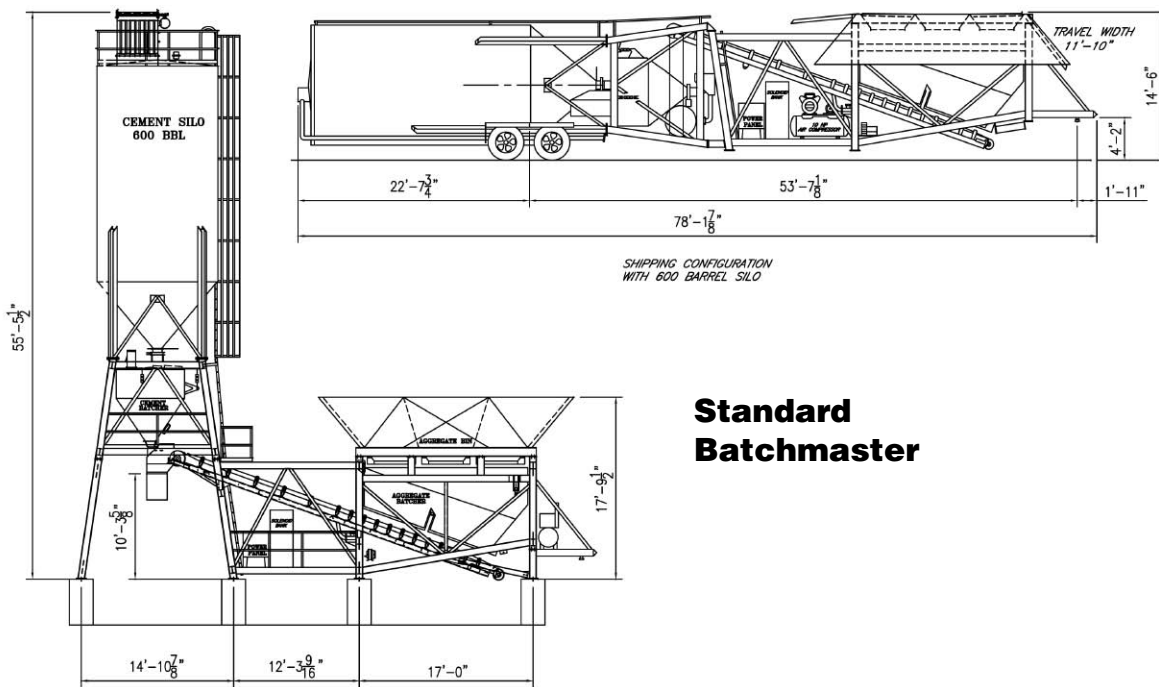

Standard Batchmaster

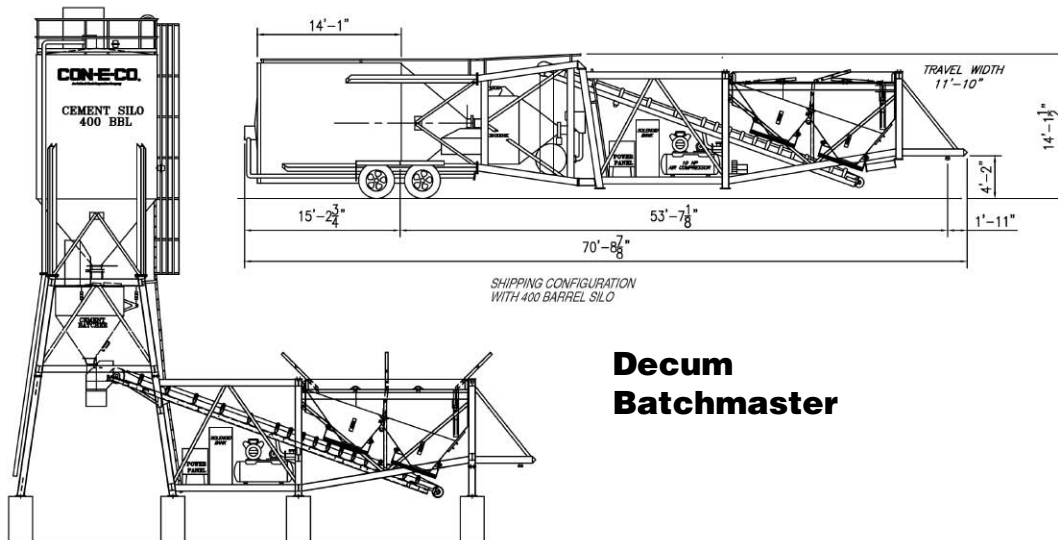

Decum Batchmaster

STANDARD BATCHMASTER SPECIFICATIONS

PRODUCTION CAPACITY:

Theoretical capacity — 150 to 200 cubic yards per hour (110 to 165 cubic meters per hour).

BATCHER CAPACITY:

Aggregate — Oversized, 12 cubic yards (9.2 cubic meters).
Cement — Oversized, 12 cubic yards (9.2 cubic meters).
Scales — Direct load cells and digital readouts.

AGGREGATE DISCHARGE CONVEYOR:

30" wide (0.76 meters) with 20 horsepower drive.
Optional: 36" wide (0.44 meters) with 25 horsepower drive.

CEMENT AERATION:

5 horsepower, high volume, low pressure blower.

HIGH PRESSURE AIR COMPRESSOR:

10 horsepower with 120 gallon (0.45 cubic meter) receiver.
Optional: 15 horsepower.

ELECTRICAL:

200 amp, 3 phase with 120 VAC transformer for control voltage. All motors are TEFC. All motor circuit wiring protected by individual circuit breakers. Electrical components housed in NEMA 12 dust-tight steel enclosure. Wiring in conduit. Minimum service size: 100 KVA.

WATER METER:

3" Badger Turbo.

STORAGE BIN CAPACITIES* Gross Volume:

Aggregate Bin — 48 to 200 cubic yards.
Cement — 565 BBL (2,260 cubic feet) to 1,065 BBL (4,260 cubic feet)
Optional: Two-compartment.

*Based on maximum bin designs.

NOTE: In accordance with CON-E-CO's policy of constantly improving its products, the above specifications are subject to change without notice. CON-E-CO assumes no responsibility for foundation design. Consult factory for column loadings.

CON-E-CO®

An Oshkosh Truck Corporation Company

McNeilus®